



3,5" Ceramic Midrange

Program Power	90 W
Rated impedance	4 Ohm
Nominal diameter	3,5" - 87 mm
Sensitivity (1W/1m)	89 dB
Voice coil diameter	0,78 in - 20 mm
Frequency Range	150-10000 Hz

SPECIFICATIONS

Nominal Diameter	3,5" - 87 mm
Rated Impedance	4 Ohm
Nominal Power Handling ¹	30 W
Program Power ²	90 W
Sensitivity ³	89 dB
Frequency Range ⁴	150-10000 Hz
Minimum Impedance	-
Basket Material	Steel
Magnet Material	Ferrite
Cone Material	Cellulose fiber
Cone Shape	-
Surround	Polyurethane
Suspension	-
Voice Coil Diameter	0,78 in - 20 mm
Voice Coil Winding Material	-
Voice Coil Length	5 mm
Voice Coil Former Material	Aluminum
Connection type	Faston
Ferrofluid	No
Magnetic Gap Height	4 mm - 0,16 in
Max. Peak to Peak Excursion	-
Efficiency Bandwidth Product EBP	153
Recommended Loading	Sealed box
Volume / Tuning frequency	1 Lt (dm ³) - 0,035 cuft
Maximum recommended frequency	-

FREQUENCY RESPONSE AND IMPEDANCE CURVE ^{6 7}

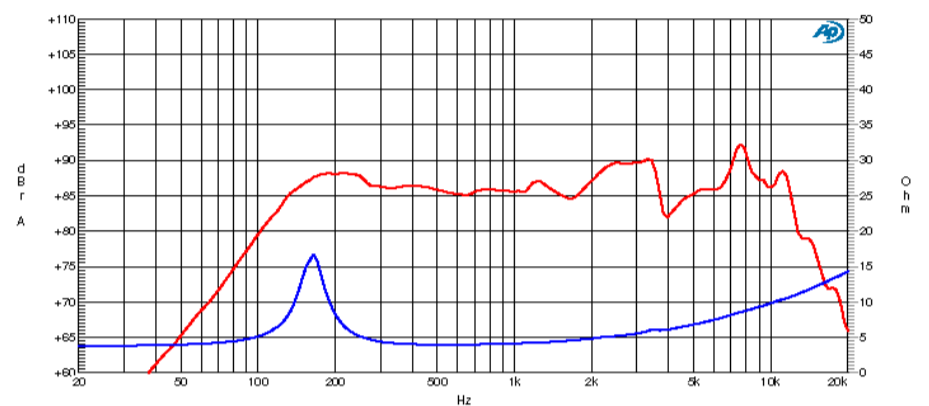

T/S PARAMETERS

4 Ohm

Resonance frequency	Fs	122 Hz
DC Resistance	Re	3,5 Ohm
Mechanical Q Factor	Qms	3,2
Electrical Q Factor	Qes	0,8
Total Q Factor	Qts	0,64
BI Factor	Bl	2,86 Tm
Effective Moving Mass	Mms	2,5 g
Equivalent Gas air loaded	Vas	1,2 lt (dm ³) - 0,04 cuft
Suspension Compliance	Cms	0,7 mm/N
Effective Piston Diameter	D	67 mm - 2,64 in
Effective piston area	Sd	35 cm ² - 5,43 sq in
Max. Linear Excursion ⁵	Xmax	1,5 mm - 0,06 in
Voice Coil Inductance @ 1kHz	Le	0,14 mH
Half-space Efficiency	η0	-

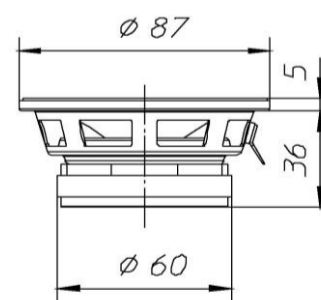

MOUNTING AND SHIPPING INFORMATION

Overall Diameter	87 mm - 3,43 in
Baffle Cutout Diameter	77 mm - 3,03 in
Flange and Gasket Thickness	5 mm - 0,2 in
Total Depth	41 mm - 1,61 in
Bolt Circle Diameter	- -
Bolt Holes Quantity and Diameter	- / - -
Net Weight	0,33 Kg - 0,73 lb
Shipping Units	12 Pcs

NOTES

¹ Nominal power is determined according to AES2-1984 (r2003) standard.

² Program Power is defined as 3 dB greater than the Nominal rating.

³ Sensitivity represents the averaged value of acoustic output as measured on the forward central axis of cone, at distance 1m, when connected to 2,83V sine wave test signal.

⁴ Frequency range is given as the band of frequencies delineated by the lower and upper limits where the output level drops by 10 dB below the rated sensitivity in half space environment.

⁵ Linear Math. Xmax is calculated as (Hvc-Hg)/2 + Hg/4 where Hvc is the coil depth and Hg is the gapdepth.

⁶ Frequency response curve is measured on infinite baffle conditions.

⁷ Impedance curve is measured in free air conditions at small signals.